

Full lift safety valve with spring loading.(AIT)

Model 496

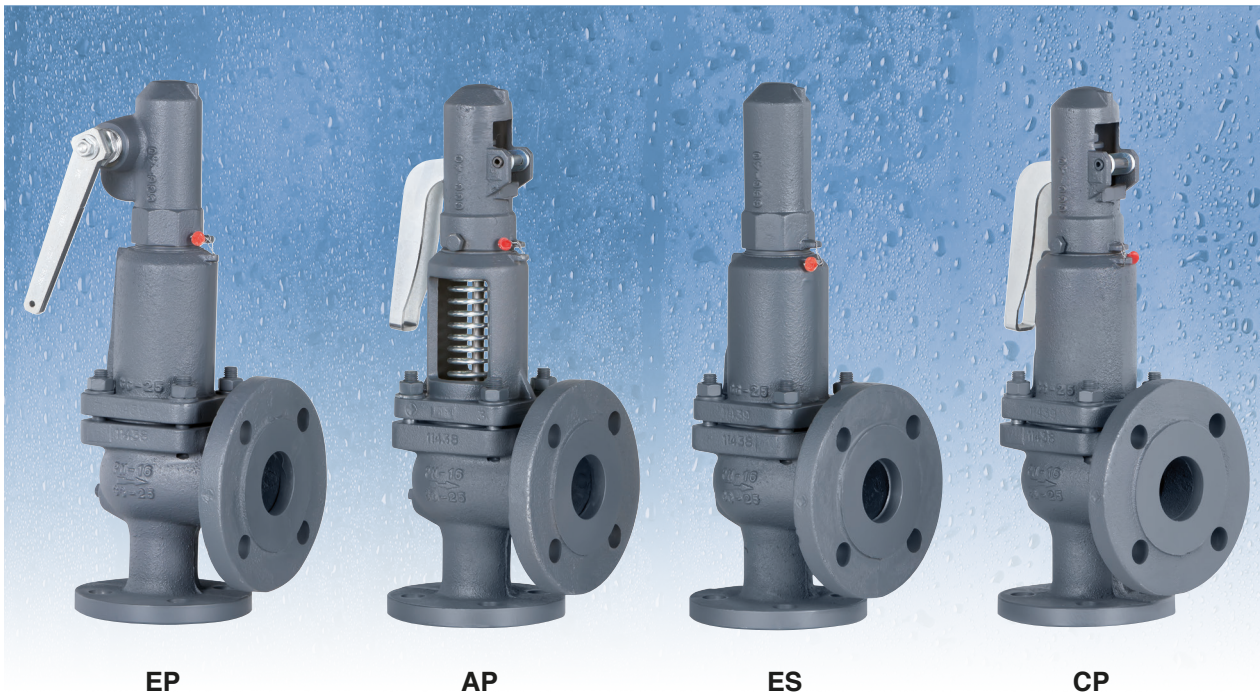

EN



The valve works as an automatic pressure releasing regulator activated by the static pressure existing at the entrance to the valve and is characterized by its ability to open instantly and totally.

Design in accordance with "International Standard ISO 4126-1 Safety Valves".

In accordance with the requirements of the pressure equipment directive 2014/68/EU.

EC valve verification certified by: TÜV Rheinland Industrie Service GmbH, Notified Body for Pressure Equipment ID-No. 0035.

Type (Module B) EC nº DEP-B-prod.001072-22 certified by: TÜV Rheinland Ibérica ICT, S.A.

In compliance with the ATEX 2014/34/EU directive "Protective equipment and systems for use in potentially explosive atmospheres".

Other authorisations: ISCIR, ITI, NASTHOL, EAC, ...etc.

Specifications

- 90° angular flow.
- Activated by direct action helicoid spring.
- Simplicity of construction ensuring minimum maintenance.
- Materials carefully selected for their resistance to corrosion. With the exception of washers and couplings, the valves are free of non-ferric materials.
- Internal body designed to offer favourable flow profile.
- Sealing surfaces treated and balanced, making them extremely tightness, even exceeding EN 12266-1 requirements.
- Great discharge capacity. For liquids typically used with openings similar to proportional safety valves.
- Equipped with draining screws for removing condensation.
- Auto-centering plug.
- Threaded shaft with lever positioner facilitating immediate manual action.
- Elevator, independent of the seal, designed facilitate sudden opening when the steam expands and, with any fluid, guarantees absolute opening and closing precision.
- All the valves are supplied sealed at the set pressure requested, simulating operational conditions, and are vigorously tested.
- All components are numbered, registered and checked. If requested in advance, material, casting, test and efficiency certificates will be enclosed with the valve, and the instruction manual, in accordance with P.E.D. 2014/68/EU.

IMPORTANT

Depending on demand:

- 1.- Blocking screw which facilitates hydrostatic testing of the container which to be protected.
- 2.- Rapid limiter to reduce the coefficient of discharge.
- 3.- Fluorelastomer (Vitón) seals, Silicone's rubber, PTFE (Teflón)... etc., achieving leakage levels less than $0,3 \times 10^{-3} \frac{\text{Pa cm}^3}{\text{seg.}}$

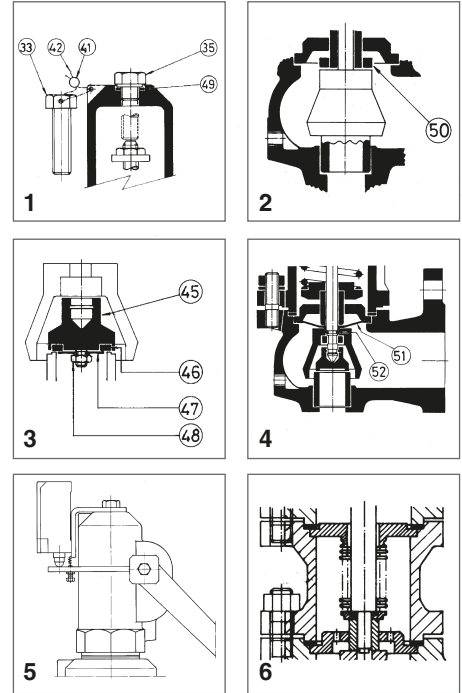

The ranges of application allow certain flexibility although we recommend limiting them to:

| RANGE OF APPLICATION FOR THE SEALS | | | | | | | |
|------------------------------------|----------------------------|---------|--------------------|---------|----------|----|------|
| FLUID | SET PRESSURE [bar] | | | | | | |
| | 0,2 | 1,8 | 4,0 | 4,8 | 7,0 | 30 | 40,0 |
| Saturated steam | S | V | | | T | | |
| Liquids and gases | | S | | V | | T | |
| SEALS | TEMPERATURE [°C] | | | | | | |
| | ACCORDING TO MANUFACTURERS | | RECOMMENDED BY VYC | | | | |
| | | MINIMUM | MAXIMUM | MINIMUM | MAXIMUM | | |
| Silicone's rubber | S | -60 | +200 | -50 | +115 | | |
| Fluorelastomer (Vitón) | V | -40 | +250 | -30 | +150 | | |
| PTFE (Teflón) | T | -265 | +260 | -80 | +230 (1) | | |

(1) For temperatures exceeding 230 °C apply metallic seal only.

- 4.- Fluorelastomer (Vitón) membrane and O-ring isolating the rotating or sliding parts from the working fluid.
- 5.- Electrical contact indicating open/closed.
- 6.- Balance bellows to:
 - Protect the spring from atmospheric influences.
 - Ensure outside of valve body is totally tightness.
 - Level out external or self-generated back pressure.
- 7.- Possibility of manufacture in other types of material, for special operating conditions (high temperatures, fluids, etc.).
- 8.- Totally free of oil and grease, to work with oxygen, avoiding possible fire risks (UV-Oxygen-VBG 62).
- 9.- Special springs for critical temperatures.

| Nº. PIECE | PIECE | MATERIAL | | | | | | | | | | | | | | | | | | | |
|-----------------------------------|----------------------|---------------------------------------|-----|-----|-----|---------------------------------------|-----|-----|-----|---------------------------------------|-----|-----|-----|----------------------------------|-----|-----|-----|-----|-----|-----|-----|
| | | CAST IRON | | | | NODULAR IRON | | | | CAST STEEL | | | | STAINLESS STEEL | | | | | | | |
| 1 | Body | Cast iron (EN-5.1301) | | | | Nodular iron (EN-5.3106) | | | | Cast steel (EN-1.0619+N) | | | | Stainless steel (EN-1.4408) | | | | | | | |
| 2 | Closed bell | Cast iron (EN-5.1301) | | | | Nodular iron (EN-5.3106) | | | | Nodular iron (EN-5.3106) | | | | Stainless steel (EN-1.4408) | | | | | | | |
| 3 | Open bell | Cast iron (EN-5.1301) | | | | Nodular iron (EN-5.3106) | | | | Nodular iron (EN-1.0619+N) | | | | Stainless steel (EN-1.4408) | | | | | | | |
| 4, 5, 6 | Hood | Nodular iron (EN-5.3106) | | | | Nodular iron (EN-5.3106) | | | | Nodular iron (EN-5.3106) | | | | Stainless steel (EN-1.4408) | | | | | | | |
| 7 | Elevator | Nodular iron (EN-5.3106) (1) | | | | Nodular iron (EN-5.3106) (1) | | | | Nodular iron (EN-5.3106) (1) | | | | Stainless steel (EN-1.4408)(7) | | | | | | | |
| 8 | Cam | Carbon steel (EN-1.0037 St-37.2) (6) | | | | Carbon steel (EN-1.0037 St-37.2) (6) | | | | Carbon steel (EN-1.0037 St-37.2) (6) | | | | Stainless steel (EN-1.4301) | | | | | | | |
| 9, 10 | Lever | Carbon steel (EN-1.0037 St-37.2) | | | | Carbon steel (EN-1.0037 St-37.2) | | | | Carbon steel (EN-1.0037 St-37.2) | | | | Carbon steel (EN-1.0037 St-37.2) | | | | | | | |
| 11 | Seating | Stainless steel (EN-1.4028) | | | | Stainless steel (EN-1.4028) | | | | Stainless steel (EN-1.4028) | | | | Stainless steel (EN-1.4542) | | | | | | | |
| 12 | Plug | Stainless steel (EN-1.4028) | | | | Stainless steel (EN-1.4028) | | | | Stainless steel (EN-1.4028) | | | | Stainless steel (EN-1.4542) | | | | | | | |
| 13 | Lead | Stainless steel (EN-1.4028) (4) | | | | Stainless steel (EN-1.4028) (4) | | | | Stainless steel (EN-1.4028) (4) | | | | Stainless steel (EN-1.4401) (5) | | | | | | | |
| 14 | Spring press | Carbon steel (EN-1.1191) | | | | Carbon steel (EN-1.1191) | | | | Carbon steel (EN-1.1191) | | | | Stainless steel (EN-1.4305) | | | | | | | |
| 15 | Separator | Stainless steel (EN-1.4028) | | | | Stainless steel (EN-1.4028) | | | | Stainless steel (EN-1.4028) | | | | Stainless steel (EN-1.4401) | | | | | | | |
| 16 | Rod | Stainless steel (EN-1.4028) | | | | Stainless steel (EN-1.4028) | | | | Stainless steel (EN-1.4028) | | | | Stainless steel (EN-1.4401) | | | | | | | |
| 17 | Lever shaft | Carbon steel (EN-1.1191) | | | | Carbon steel (EN-1.1191) | | | | Carbon steel (EN-1.1191) | | | | Stainless steel (EN-1.4305) | | | | | | | |
| 18 | Gudgeon | Carbon steel (EN-1.1231) | | | | Carbon steel (EN-1.1231) | | | | Carbon steel (EN-1.1231) | | | | Stainless steel (EN-1.4310) | | | | | | | |
| 19 | Ring | Stainless steel (EN-1.4028) | | | | Stainless steel (EN-1.4028) | | | | Stainless steel (EN-1.4028) | | | | Stainless steel (EN-1.4401) | | | | | | | |
| 20, 21 | Safety ring | Stainless steel (EN-1.4310) | | | | Stainless steel (EN-1.4310) | | | | Stainless steel (EN-1.4310) | | | | Stainless steel (EN-1.4310) | | | | | | | |
| 22 | Spring | Vanadium chrome steel (EN-1.8159) (2) | | | | Vanadium chrome steel (EN-1.8159) (2) | | | | Vanadium chrome steel (EN-1.8159) (2) | | | | Stainless steel (EN-1.4310) (3) | | | | | | | |
| 23 | Gland | Carbon steel (EN-1.1191) | | | | Carbon steel (EN-1.1191) | | | | Carbon steel (EN-1.1191) | | | | Stainless steel (EN-1.4305) | | | | | | | |
| 24 | Hollow screw | Stainless steel (EN-1.4305) | | | | Stainless steel (EN-1.4305) | | | | Stainless steel (EN-1.4305) | | | | Stainless steel (EN-1.4305) | | | | | | | |
| 25 | Hollow screw nut | Stainless steel (EN-1.4305) | | | | Stainless steel (EN-1.4305) | | | | Stainless steel (EN-1.4305) | | | | Stainless steel (EN-1.4305) | | | | | | | |
| 26 | Buffer nut | Stainless steel (EN-1.4305) | | | | Stainless steel (EN-1.4305) | | | | Stainless steel (EN-1.4305) | | | | Stainless steel (EN-1.4305) | | | | | | | |
| 27 | Rod check nut | Carbon steel (EN-1.1141) | | | | Carbon steel (EN-1.1141) | | | | Carbon steel (EN-1.1141) | | | | Stainless steel (EN-1.4401) | | | | | | | |
| 28, 29, 48 | Nut | Carbon steel (EN-1.1141) | | | | Carbon steel (EN-1.1141) | | | | Carbon steel (EN-1.1141) | | | | Stainless steel (EN-1.4401) | | | | | | | |
| 30, 31 | Washer | Carbon steel (EN-1.1141) | | | | Carbon steel (EN-1.1141) | | | | Carbon steel (EN-1.1141) | | | | Stainless steel (EN-1.4401) | | | | | | | |
| 32 | Stud | Carbon steel (EN-1.1181) | | | | Carbon steel (EN-1.1181) | | | | Carbon steel (EN-1.1181) | | | | Stainless steel (EN-1.4401) | | | | | | | |
| 33, 34, 35 | Screw | Carbon steel (EN-1.1191) | | | | Carbon steel (EN-1.1191) | | | | Carbon steel (EN-1.1191) | | | | Stainless steel (EN-1.4401) | | | | | | | |
| 36 | Cap | Carbon steel (EN-1.1181) | | | | Carbon steel (EN-1.1181) | | | | Carbon steel (EN-1.1181) | | | | Stainless steel (EN-1.4401) | | | | | | | |
| 38 | Coupling | Graphite | | | | Graphite | | | | Graphite | | | | PTFE (Teflón) | | | | | | | |
| 39 | Coupling | PTFE (Teflón) | | | | PTFE (Teflón) | | | | PTFE (Teflón) | | | | PTFE (Teflón) | | | | | | | |
| 40 | Seal | Graphite | | | | Graphite | | | | Graphite | | | | PTFE (Teflón) | | | | | | | |
| 41 | Seal | Plastic | | | | Plastic | | | | Plastic | | | | Plastic | | | | | | | |
| 42 | Sealing wire | Sealing wire | | | | Sealing wire | | | | Sealing wire | | | | Sealing wire | | | | | | | |
| 43 | Characteristic plate | Stainless steel (EN-1.4301) | | | | Stainless steel (EN-1.4301) | | | | Stainless steel (EN-1.4301) | | | | Stainless steel (EN-1.4301) | | | | | | | |
| 45 | Plug | Stainless steel (EN-1.4401) | | | | Stainless steel (EN-1.4401) | | | | Stainless steel (EN-1.4401) | | | | Stainless steel (EN-1.4401) | | | | | | | |
| 46 | Sealing disk | PTFE (Teflón) | | | | PTFE (Teflón) | | | | PTFE (Teflón) | | | | PTFE (Teflón) | | | | | | | |
| | | Silicone's rubber | | | | Silicone's rubber | | | | Silicone's rubber | | | | Silicone's rubber | | | | | | | |
| | | Fluorelastomer (Vitón) | | | | Fluorelastomer (Vitón) | | | | Fluorelastomer (Vitón) | | | | Fluorelastomer (Vitón) | | | | | | | |
| 47 | Washer | Stainless steel (EN-1.4401) | | | | Stainless steel (EN-1.4401) | | | | Stainless steel (EN-1.4401) | | | | Stainless steel (EN-1.4401) | | | | | | | |
| 49 | Coupling | Copper | | | | Copper | | | | Copper | | | | PTFE (Teflón) | | | | | | | |
| 50 | Limiter | Stainless steel (EN-1.4028) | | | | Stainless steel (EN-1.4028) | | | | Stainless steel (EN-1.4028) | | | | Stainless steel (EN-1.4401) | | | | | | | |
| 51 | Membrane | Fluorelastomer (Vitón) | | | | Fluorelastomer (Vitón) | | | | Fluorelastomer (Vitón) | | | | Fluorelastomer (Vitón) | | | | | | | |
| 52 | O-ring | Fluorelastomer (Vitón) | | | | Fluorelastomer (Vitón) | | | | Fluorelastomer (Vitón) | | | | Fluorelastomer (Vitón) | | | | | | | |
| DN ₁ x DN ₂ | | 20 x 32 to 200 x 300 | | | | | | | | | | | | | | | | | | | |
| PN | | 16 | | | | 40 | | | | 40 | | | | 40 | | | | | | | |
| OPERATING CONDITIONS | PRESSURE [bar] | 16 | 13 | 13 | 13 | 40 | 35 | 32 | 28 | 24 | 40 | 35 | 32 | 28 | 24 | 21 | 20 | 40 | 34 | 32 | 29 |
| | MAX. TEMP. [°C] | 120 | 200 | 250 | 300 | 120 | 200 | 250 | 300 | 350 | 120 | 200 | 250 | 300 | 350 | 400 | 450 | 120 | 200 | 250 | 400 |
| | MIN. TEMP. [°C] | -10 | | | | -10 | | | | -10 | | | | -60 | | | | | | | |

(1) DN-20 x 32 in stainless steel (EN-1.4408).

(2) Spring steel (EN-10270-1-SH) for wire spring Ø < 10 mm. Maximum temperature EP, ES and CP 250 °C / AP 400 °C.

(3) Vanadium chrome steel (EN-1.8159) for wire spring Ø > 10 mm.

(4) DN-200x300 in Stainless steel (DIN-1.4027).

(5) DN-200x300 in Stainless steel (EN-1.4408).

(6) DN-20x32 in Stainless steel (DIN-1.4301).

(7) DN-32x50 to DN-65x100 in Stainless steel (DIN-1.4401).

Full lift safety valve with spring loading (AIT) model 496 - AP and CP.

1. Disassembly and assembly.

1.1 Disassembly.

To replace the spring (22) or clean any of the internal components of the valve, proceed in the following manner:

A - Withdraw the clip (18), using a punching tool, until the lever (10) comes free.

B - Loosen the screws (34) and take the cap (6) off.

C - Holding the spindle (16) steady, loosen the hollow screw nut (25) and the hollow screw (24) until you note a releasing of the spring (22).

D - Mark on the spindle (16) the position of the spindle lock-nut (27) and the adjusting nut (26). Loosen them and remove them.

E - Unscrew the nuts (29) and remove them, together with the studs (32) and their washers (30).

F - Lift the cover (3) or (2) and you will have access to all of the components.

1.2 Assembly.

A - Place the safety-ring (20) on the spindle (16) and press it against the gasket (12).

B - In the spindle channel (16) connect the ring (19) and fix it to the security-ring (21). Introduce the elevator (7) into the upper part of the spindle (16) and press this against the previously described pieces.

C - Enter the guide (13), the separator (15), the spring-press (14), the spring (22), the spring-press (14) through the upper part of the spindle (16) and press this against the previously described pieces.

D - Replace the assembly (38) and the cover (3) or (2).

E - Place the washers (30) on the studs (32) and make up the nuts (29) diagonally, checking the correct alignment of the cover (3) or (2).

F - Adjust the firing pressure with the hollow screw (24) and fix the adjustment position with the hollow screw nut (25).

G - Turn the spindle lock-nut (27) and the adjusting nut (26) to the position marked (see 1.1.D) and make up against each other.

H - Introduce the cap (6) and tighten the screws (34).

I - Place the lever (10) and fix it with the fastener (18).

2. Adjusting the firing pressure.

A - Proceed according to points 1.1.A, 1.1.B, 1.1.C.

B - Proceed according to points 1.2.F, 1.2.H, 1.2.I.

Full lift safety valve with spring loading (AIT) model 496 - EP.

1. Disassembly and assembly .

1.1 Disassembly.

To replace the spring (22), or clean any of the internal components of the valve, proceed in the following manner:

A - Move the lever (9) in direction C as far as the constructive catcher.

B - Unscrew the cap (4) and remove.

C - Holding the spindle (16) steady, loosen the hollow screw nut (25) and the hollow screw (24) until you note a releasing of the spring (22).

D - Mark on the spindle (16) the position of the spindle lock-nut (27) and the adjusting nut (26). Loosen them and remove them.

E - Unscrew the nuts (29) and remove them, together with the studs (32) and their washers (30).

F - Lift the cover (2) and you will have access to all of the components.

1.2 Assembly.

A - Place the safety-ring (20) on the spindle (16) and press it against the gasket (12).

B - In the spindle channel (16) connect the ring (19) and fix it to the security-ring (21). Introduce the elevator (7) into the upper part of the spindle (16) and press this against the previously described pieces.

C - Enter the guide (13), the separator (15), the spring-press (14), the spring (22), the spring-press (14) through the upper part of the spindle (16) in a correlative manner.

D - Replace the assembly (38) and the cover (2).

E - Place the washers (30) on the studs (32) and make up the nuts (29) diagonally, checking the correct alignment of the cover (2).

F - Adjust the firing pressure with the hollow screw (24) and fix the adjustment position with the hollow screw nut (25).

G - Turn the spindle lock-nut (27) and the adjusting nut (26) to the position marked (see 1.1.D) and make up against each other.

H - Change the coupling (39) and lightly tighten the cap (4). Move the lever (9) towards position A as far as the constructive catcher. Definitively tighten the cap (4).

2. Adjustig the firing pressure.

A - Proceed according to points 1.1.A, 1.1.B, 1.1.C.

B - Proceed according to points 1.2.F, 1.2.H.

Full lift safety valve with spring loading (AIT) model 496 - ES.

1. Disassembly and assembly.

1.1 Disassembly.

To replace the spring (22), or clean any of the internal components of the valve, proceed in the following manner:

A - Unscrew the cap (5) and remove.

B - Holding the spindle (16) steady, loosen the hollow screw nut (25) and the hollow screw (24) until you note a releasing of the spring (22).

C - Unscrew the nuts (29) and remove them, together with the studs (32) and their washers (30).

F - Lift the cover (2) and you will have access to all of the components.

1.2 Assembly.

A - Place the safety-ring (20) on the spindle (16) and press it against the gasket (12).

B - In the spindle channel (16) connect the ring (19) and fix it to the security-ring (21).

Introduce the elevator (7) into the upper part of the spindle (16) and press this against the previously described pieces.

C - Enter the guide (13), the separator (15), the spring-press (14), the spring (22), the spring-press (14) through the upper part of the spindle (16) in a correlative manner.

D - Replace the washers (38) and the cover (2).

E - Place the washers (30) on the studs (32) and make up the nuts (29) diagonally, checking the correct alignment of the cover (2).

F - Adjust the firing pressure with the hollow screw (24) and fix the adjustment position with the hollow screw nut (25).

G - Change the coupling (39) and tighten the cap (5).

2. Adjusting the firing pressure.

A - Proceed according to points 1.1.A, 1.1.B.

B - Proceed according to points 1.2.F, 1.2.G.

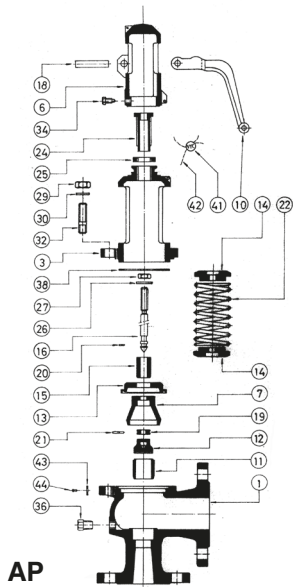

AP

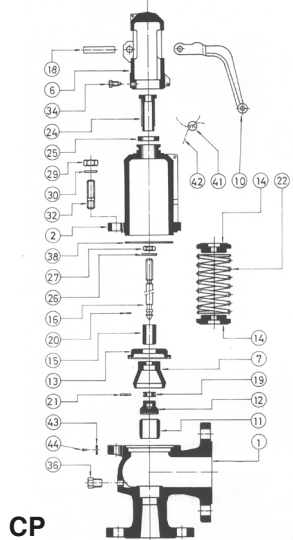

CP

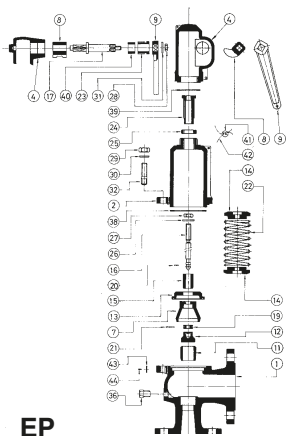

EP

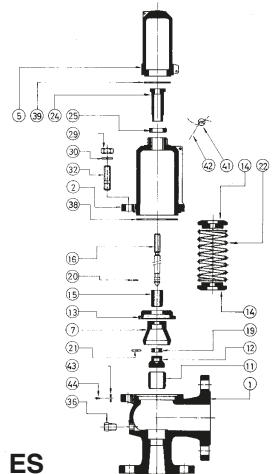

ES

| DN1 x DN2 | 20 x 32 | 25 x 40 | 32 x 50 | 40 x 65 | 50 x 80 | 65 x 100 | 80 x 125 | 100 x 150 | 125 x 200 | 150 x 250 | 200 x 300 | | | | | | | | | | | | | | | | | | | | | | | | | | | | | | | | | | | |
|---|----------------------------|----------------|---------|---------|---------|----------|----------|--------------|-----------|--------------|-----------|---------|---------|---------|-------|-------|-------|-------|-------|-------|-------|-------|-------|-------|-------|-------|-------|-------|-------|-------|-------|-------|-------|-------|--------|-------|--------|--------|--------|--------|--------|--------|--------|--------|--------|--------|
| do | 16 | 20 | 25 | 32 | 40 | 50 | 63 | 77 | 93 | 110 | 155 | | | | | | | | | | | | | | | | | | | | | | | | | | | | | | | | | | | |
| $A_0 = \frac{\pi \cdot do^2}{4}$ | 201 | 314 | 491 | 804 | 1257 | 1964 | 3117 | 4657 | 6793 | 9503 | 18870 | | | | | | | | | | | | | | | | | | | | | | | | | | | | | | | | | | | |
| H | 350 | 395 | 415 | 500 | 555 | 660 | 710 | 810 | 858 | 1029 | 1252 | | | | | | | | | | | | | | | | | | | | | | | | | | | | | | | | | | | |
| h ₁ | 112 | 129 | 129 | 148 | 148 | 191 | 191 | 191 | 191 | 247 | 331 | | | | | | | | | | | | | | | | | | | | | | | | | | | | | | | | | | | |
| L ₁ | 85 | 95 | 100 | 115 | 125 | 140 | 155 | 175 | 215 | 225 | 265 | | | | | | | | | | | | | | | | | | | | | | | | | | | | | | | | | | | |
| L ₂ | 95 | 105 | 110 | 130 | 145 | 150 | 170 | 180 | 220 | 245 | 290 | | | | | | | | | | | | | | | | | | | | | | | | | | | | | | | | | | | |
| R | 1/4" | 1/4" | 1/4" | 1/4" | 1/4" | 3/8" | 3/8" | 3/8" | 1/2" | 1/2" | 1/2" | | | | | | | | | | | | | | | | | | | | | | | | | | | | | | | | | | | |
| Whitworth gas-tight cylindrical female thread ISO 228/1 (DIN-259) | | | | | | | | | | | | | | | | | | | | | | | | | | | | | | | | | | | | | | | | | | | | | | |
| INTAKE FLANGE | PN-10/16 EN-1092-2 (2) | D ₁ | 105 | 115 | 140 | 150 | 165 | 185 | 200 | 220 | 250 | 285 | 340 | | | | | | | | | | | | | | | | | | | | | | | | | | | | | | | | | |
| | | K ₁ | 75 | 85 | 100 | 110 | 125 | 145 | 160 | 180 | 210 | 240 | 295 | | | | | | | | | | | | | | | | | | | | | | | | | | | | | | | | | |
| | | l ₁ | 14 | 14 | 19 | 19 | 19 | 19 | 19 | 19 | 19 | 23 | 23 | | | | | | | | | | | | | | | | | | | | | | | | | | | | | | | | | |
| | | b ₁ | 16 | 16 | 18 | 18 | 20 | 20 | 22 | 24 | 26 | 26 | 26 | | | | | | | | | | | | | | | | | | | | | | | | | | | | | | | | | |
| | | DRILLS N.º | 4 | 4 | 4 | 4 | 4 | 4 | 8 | 8 | 8 | 8 | 8 | | | | | | | | | | | | | | | | | | | | | | | | | | | | | | | | | |
| INTAKE FLANGE | EN-1092-2 EN-1092-1 (3) | D ₁ | 105 | 115 | 140 | 150 | 165 | 185 | 200 | 235 | 270 | 300 | 360 | | | | | | | | | | | | | | | | | | | | | | | | | | | | | | | | | |
| | | K ₁ | 75 | 85 | 100 | 110 | 125 | 145 | 160 | 190 | 220 | 250 | 310 | | | | | | | | | | | | | | | | | | | | | | | | | | | | | | | | | |
| | | l ₁ | 14 | 14 | 19(18)* | 19(18)* | 19(18)* | 19(18)* | 19(18)* | 19(18)* | 23(22)* | 28(26)* | 28(26)* | 28(26)* | | | | | | | | | | | | | | | | | | | | | | | | | | | | | | | | |
| | | b ₁ | 18(16)* | 18(16)* | 18 | 18(20)* | 20 | 22 | 24 | 24 | 26 | 28 | 30 | | | | | | | | | | | | | | | | | | | | | | | | | | | | | | | | | |
| | | DRILLS N.º | 4 | 4 | 4 | 4 | 4 | 4 | 8 | 8 | 8 | 8 | 12 | | | | | | | | | | | | | | | | | | | | | | | | | | | | | | | | | |
| ESCAPE FLANGE | EN-1092-2 EN-1092-1 (1) | D ₂ | 140 | 150 | 165 | 185 | 200 | 220 | 250 | 285 | 340 | 395 | 445 | | | | | | | | | | | | | | | | | | | | | | | | | | | | | | | | | |
| | | K ₂ | 100 | 110 | 125 | 145 | 160 | 180 | 210 | 240 | 295 | 350 | 400 | | | | | | | | | | | | | | | | | | | | | | | | | | | | | | | | | |
| | | l ₂ | 19(18)* | 19(18)* | 19(18)* | 19(18)* | 19(18)* | 19(18)* | 19(18)* | 19(18)* | 23(22)* | 23(22)* | 23(22)* | 23(22)* | | | | | | | | | | | | | | | | | | | | | | | | | | | | | | | | |
| | | b ₂ | 18 | 18 | 20 | 20(18)* | 22(20)* | 24(22)*(20)* | 26(22)* | 26(24)*(22)* | 26(24)* | 28(26)* | 28(26)* | | | | | | | | | | | | | | | | | | | | | | | | | | | | | | | | | |
| | | DRILLS N.º | 4 | 4 | 4 | 4 | 8 | 8 | 8 | 8 | 8 | 12 | 12 | | | | | | | | | | | | | | | | | | | | | | | | | | | | | | | | | |
| WEIGHT IN kgs | MODEL | EP | AP | ES | CP | EP | AP | ES | CP | EP | AP | ES | CP | EP | AP | ES | CP | EP | AP | ES | CP | EP | AP | ES | CP | EP | AP | ES | CP | EP | AP | ES | CP | | | | | | | | | | | | | |
| | CAST IRON | 800 | 740 | 760 | 780 | 960 | 888 | 912 | 938 | 13,87 | 12,82 | 13,17 | 13,43 | 20,27 | 18,74 | 19,25 | 10,68 | 26,68 | 24,67 | 25,34 | 25,77 | 39,48 | 36,52 | 37,50 | 38,10 | 55,48 | 51,32 | 52,70 | 53,30 | 82,15 | 75,98 | 78,04 | 78,64 | 94,50 | 88,64 | 92,80 | 95,38 | 95,84 | 133,10 | 130,80 | 135,10 | 136,37 | 228,10 | 214,60 | 221,72 | 224,30 |
| | NODULAR IRON | 873 | 807 | 829 | 849 | 1047 | 968 | 994 | 1020 | 15,13 | 13,99 | 14,37 | 14,63 | 22,11 | 20,45 | 21,00 | 11,43 | 28,11 | 26,92 | 27,65 | 28,08 | 43,08 | 39,84 | 40,92 | 41,52 | 60,54 | 54,09 | 57,53 | 58,11 | 89,64 | 82,91 | 85,15 | 85,75 | 97,00 | 91,16 | 95,38 | 95,84 | 133,10 | 130,80 | 135,10 | 136,37 | 228,10 | 214,60 | 221,72 | 224,30 | |
| | CAST STEEL STAINLESS STEEL | 850 | 786 | 807 | 827 | 1030 | 950 | 976 | 1002 | 10,33 | 14,87 | 13,75 | 14,12 | 14,38 | 21,27 | 19,67 | 20,20 | 10,63 | 26,68 | 26,52 | 27,24 | 27,67 | 41,48 | 38,36 | 39,40 | 40,00 | 58,48 | 54,09 | 55,53 | 56,11 | 87,15 | 80,61 | 82,79 | 83,39 | 104,38 | 97,86 | 102,65 | 103,10 | 152,10 | 144,48 | 149,30 | 150,88 | 250,88 | 235,94 | 243,61 | 246,75 |
| CODE | CAST IRON 2002-496. | 8344 | 8346 | 83461 | 83462 | 83463 | 8106 | 81061 | 81062 | 81063 | 8146 | 81461 | 81462 | 81463 | 8126 | 81261 | 81262 | 81263 | 8206 | 82061 | 82062 | 82063 | 8226 | 82261 | 82262 | 82263 | 8306 | 83061 | 83062 | 83063 | 8406 | 84061 | 84062 | 84063 | 8506 | 85061 | 85062 | 85063 | 8606 | 86061 | 86062 | 86063 | 8806 | 88061 | 88062 | 88063 |
| | NODULAR IRON 2002-496. | 83441 | 83461 | 83462 | 83463 | 81061 | 81062 | 81063 | 81461 | 81462 | 81463 | 81261 | 81262 | 81263 | 82061 | 82062 | 82063 | 82261 | 82262 | 82263 | 83061 | 83062 | 83063 | 84061 | 84062 | 84063 | 85061 | 85062 | 85063 | 86061 | 86062 | 86063 | 88061 | 88062 | 88063 | | | | | | | | | | | |
| | CAST STEEL 2002-496. | 83442 | 83442 | 83442 | 83443 | 81041 | 81042 | 81043 | 81441 | 81442 | 81443 | 81241 | 81242 | 81243 | 82041 | 82042 | 82043 | 82241 | 82242 | 82243 | 83041 | 83042 | 83043 | 84041 | 84042 | 84043 | 85041 | 85042 | 85043 | 86041 | 86042 | 86043 | 88041 | 88042 | 88043 | | | | | | | | | | | |
| | STAINLESS STEEL 2002-496. | 8342 | 83421 | 83422 | 83423 | 8102 | 81021 | 81023 | 8142 | 81421 | 81423 | 8122 | 81221 | 81223 | 8202 | 82021 | 82022 | 82023 | 8222 | 82221 | 82222 | 82223 | 8302 | 83021 | 83022 | 83023 | 8402 | 84021 | 84022 | 84023 | 8502 | 85021 | 85022 | 85023 | 8602 | 86021 | 86022 | 86023 | 8802 | 88021 | 88022 | 88023 | | | | |

(1) From DN-125x200 PN-10.
(2) DN-200x300 PN-10.
(3) DN-200x300 PN-25.

* Cast steel (EN-1.0619) and Stainless steel (EN-1.4408).
• Nodular iron (EN-5.3106).

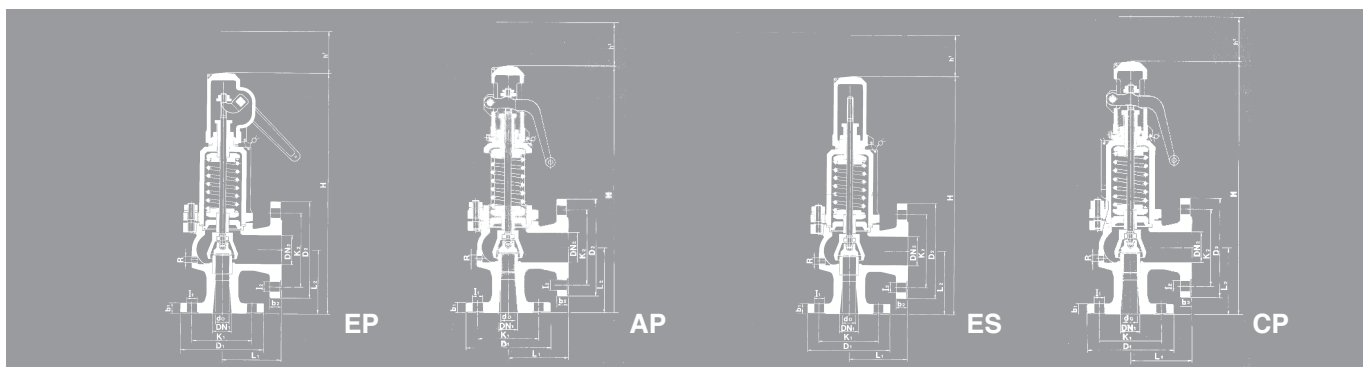

| RECOMMENDED RANGES OF APPLICATION | | | | | | |
|--|-----------------------------|-----------------------|-------|----|-------|----|
| MODEL | | EP | AP(1) | ES | CP(1) | |
| FLUID | SATURATED STEAM | * | * | | * | |
| | GASES | * | | * | | |
| | LIQUIDS | * | | | * | |
| PERMISSIBLE BACK PRESSURE IN % OF SET PRESSURE | INTERNAL OR GENERATED | SATURATED STEAM GASES | | | | 15 |
| | EXTERNAL VARIABLE (1) | SATURATED STEAM GASES | | | | 5 |
| | | LIQUIDS | | | | — |
| | EXTERNAL CONSTANT (1)(2)(3) | SATURATED STEAM GASES | | | | 50 |
| LIQUIDS | | | | 90 | | |
| % OVERPRESSURE | SATURATED STEAM GASES | | | | 10 | |
| | LIQUIDS | | | | 25 | |

| OPEN AND CLOSED PRESSURES IN % OF SET PRESSURE | | | |
|--|----------------|------------------|------------------|
| FLUID | PRESSURE [bar] | OPENING PRESSURE | CLOSING PRESSURE |
| SATURATED STEAM | < 3 | + 5 % | - 0,3 bar |
| | ≥ 3 | + 5 % | - 10 % |
| LIQUIDS | < 3 | + 10 % | - 0,6 bar |
| | ≥ 3 | + 10 % | - 20 % |

- (1) If external backpressure exists, the AP and CP model cannot be used.
- (2) With external constant backpressure, the spring is adjusted deducting the backpressure from the set pressure.
- (3) If the set pressure < 3 bar we must consider the total atmospheric pressure (1 bar) as external constant backpressure being freely released.

If $p_a > 0,25p$, we must limit plug speed with the consequent reduction of the α_d coefficient of discharge. With the new reduced coefficient we determine the d_0 , in order to remove the necessary volume..

p_a = Backpressure permitted [bar] absolute.
 p = Set pressure [bar] absolute.
 α_d = Coefficient of discharge.

SET PRESSURES AND REGULATING RANGES

| DN ₁ x DN ₂ | | | 20 x 32 | 25 x 40 | 32 x 50 | 40 x 65 | 50 x 80 | 65 x 100 | 80 x 125 | 100 x 150 | 125 x 200 | 150x250 | 200x300 | |
|-----------------------------------|--------------------------------|-----------------|----------------|----------------|----------------|----------------|----------------|----------------|----------------|----------------|-----------|---------|---------|-----|
| SET PRESSURES [bar] | MAXIMUM (LIQUIDS AND GASES) | PN-16 | 16 | 16 | 16 | 16 | 16 | 16 | 16 | 16 | 12,5 | 10 | 8 | |
| | | PN-40 | 40 | 40 | 40 | 32 | 32 | 32 | 25 | 20 | 12,5 | 10 | 8 | |
| | MAXIMUM (SATURATED STEAM) | PN-16 | 13 | 13 | 13 | 13 | 13 | 13 | 13 | 13 | 13 | 12,5 | 10 | 8 |
| | | PN-40 | 32 | 32 | 30 | 24 | 22 | 24 | 20 | 18 | 12,5 | 10 | 8 | |
| | MINIMUM | STEAM AND GASES | 0,5 | 0,5 | 0,5 | 0,5 | 0,5 | 0,5 | 0,5 | 0,5 | 0,5 | 0,5 | 0,5 | 0,5 |
| | | LIQUIDS | 0,2 | 0,2 | 0,2 | 0,2 | 0,2 | 0,2 | 0,2 | 0,2 | 0,2 | 0,2 | 0,2 | 0,2 |
| SPRING REGULATING RANGE [bar] | 0,20 to 0,68 | CODE | 56210 56390 | 56226 56406 | 56242 56422 | 56258 56438 | 56453 56453 | 56288 56468 | 56303 56483 | 56317 56497 | 56500 | 56511 | 56521 | |
| | 0,66 to 1,00 | CODE | 56211 56391 | 56227 56407 | 56243 56423 | 56259 56439 | 56454 56454 | 56289 56469 | 56304 56484 | 56318 | 56501 | 56512 | 56522 | |
| | 0,95 to 1,40 | CODE | 56212 56392 | 56228 56408 | 56244 56424 | 56260 56440 | 56455 56455 | 56290 56470 | 56305 56485 | 56319 | 56502 | 56513 | 56523 | |
| | 1,30 to 1,90 | CODE | 56213 56393 | 56229 56409 | 56245 56425 | 56261 56441 | 56456 56456 | 56291 56471 | 56306 56486 | 56320 | 56503 | 56514 | 56524 | |
| | 1,80 to 2,60 | CODE | 56214 56394 | 56230 56410 | 56246 56426 | 56262 56442 | 56457 56457 | 56292 56472 | 56307 | 56321 | 56504 | 56515 | 56525 | |
| | 2,50 to 3,60 | CODE | 56215 56395 | 56231 56411 | 56247 56427 | 56263 56443 | 56458 56458 | 56293 56473 | 56308 | 56322 | 56505 | 56516 | 56526 | |
| | 3,50 to 5,00 | CODE | 56216 56396 | 56232 56412 | 56248 56428 | 56264 56444 | 56459 56459 | 56294 | 56309 | 56323 | 56506 | 56517 | 56527 | |
| | 4,80 to 6,30 | CODE | 56217 56397 | 56233 56413 | 56249 56429 | 56265 56445 | 56460 56460 | 56295 | 56310 | 56324 | 56507 | 56518 | 56528 | |
| | 6,00 to 8,00 | CODE | 56218 56398 | 56234 56414 | 56250 56430 | 56266 56446 | 56461 56461 | 56296 | 56311 | 56325 | 56508 | 56519 | 56529 | |
| | 7,50 to 10,00 | CODE | 56219 56399 | 56235 56415 | 56251 56431 | 56267 56447 | 56462 56462 | 56297 | 56312 | 56326 | 56509 | 56520 | | |
| | 9,50 to 12,50 | CODE | 56220 56400 | 56236 56416 | 56252 56432 | 56268 56448 | 56283 | 56298 | 56313 | 56327 | 56510 | | | |
| | 12,00 to 16,00 | CODE | 56221 56401 | 56237 56417 | 56253 56433 | 56269 56449 | 56284 | 56299 | 56314 | 56328 | | | | |
| | 15,00 to 20,00 | CODE | 56222 56402 | 56238 56418 | 56254 56434 | 56270 | 56285 | 56300 | 56315 | 56329 | | | | |
| | 18,00 to 25,00 | CODE | 56223 56403 | 56239 56419 | 56255 56435 | 56271 | 56286 | 56301 | 56316 | | | | | |
| | 23,00 to 32,00 | CODE | 56224 56404 | 56240 56420 | 56256 56436 | 56272 | 56287 | 56302 | | | | | | |
| 30,00 to 40,00 | CODE | 56225 56405 | 56241 56421 | 56257 56437 | | | | | | | | | | |

- Spring steel (EN-10270-1-SH). Maximum temperature for EP, ES and CP models 250 °C / AP 400 °C.
- Vanadium-chrome steel (EN-1.8159).
- Stainless steel (EN-1.4310).

COEFFICIENT OF DISCHARGE

| DN1 x DN2 | 20 x 32 | 25 x 40 | 32 x 50 | 40 x 65 | 50 x 80 | 65 x 100 | 80 x 125 | 100 x 150 | 125x200 | 150x250 | 200x300 |
|-------------------------------|--------------------------------|---------|---------|---------|---------|----------|----------|-----------|---------|---------|---------|
| do | 16 | 20 | 25 | 32 | 40 | 50 | 63 | 77 | 93 | 110 | 155 |
| h | 7,00 | 9,00 | 12,00 | 12,00 | 18,00 | 18,00 | 20,00 | 29,00 | 34,40 | 36,80 | 56,15 |
| h1 | 2,60 | 3,20 | 4,00 | 5,20 | 6,50 | 8,00 | 10,00 | 12,50 | 16,74 | 19,80 | 27,90 |
| h/do | 0,44 | 0,45 | 0,48 | 0,38 | 0,45 | 0,36 | 0,32 | 0,38 | 0,37 | 0,33 | 0,36 |
| h1/do (1) | 0,16 | 0,16 | 0,16 | 0,16 | 0,16 | 0,16 | 0,16 | 0,16 | 0,18 | 0,18 | 0,18 |
| COEFFICIENT OF DISCHARGE [kd] | SATURATED STEAM GASES | | 0,78 | | | | | | 0,78 | 0,78 | 0,74 |
| | LIQUIDES | | 0,60 | | | | | | 0,52 | | |
| | LIQUIDS WITH RAPID LIMITER (1) | | 0,36 | | | | | | | | |

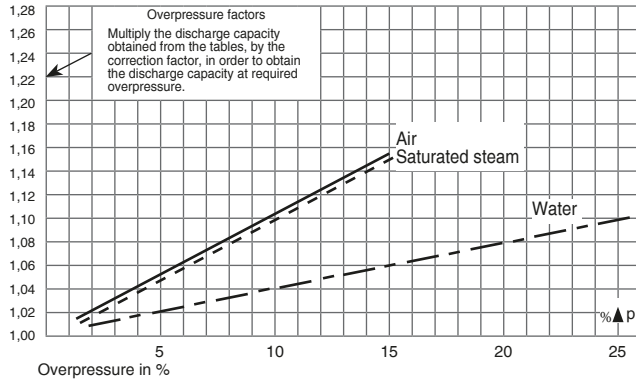
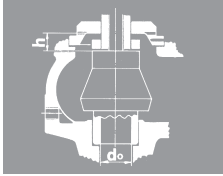

Liquids

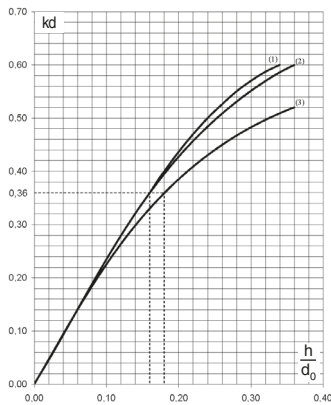

- (1) do 16-63
- (2) do 77
- (3) do 93-155

Saturated steam Gases

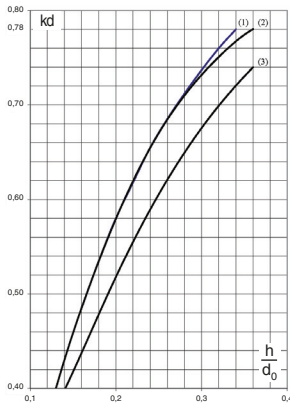

- (1) do 16-77
- (2) do 93-110
- (3) do 155

Saturated steam Gases

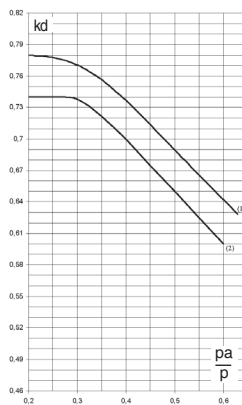

- (1) do 16-110
- (2) do 155

| DN1 x DN2 | 20 x 32 | 25 x 40 | | | | |
|----------------------------------|--------------------|---------|-------|------|------|-------|
| do | 16 | 20 | | | | |
| $A_0 = \frac{\pi \cdot do^2}{4}$ | 201 | 314 | | | | |
| p [bar] | | | | | | |
| | SET PRESSURE [bar] | | | | | |
| | I | II | III | I | II | III |
| 0,5 | 101 | 121 | 4310 | 157 | 200 | 6734 |
| 1,0 | 151 | 182 | 6096 | 236 | 285 | 9523 |
| 1,5 | 200 | 244 | 7466 | 312 | 380 | 11664 |
| 2,0 | 246 | 300 | 8621 | 385 | 469 | 13468 |
| 2,5 | 290 | 356 | 9639 | 453 | 569 | 15058 |
| 3,0 | 334 | 414 | 10559 | 522 | 648 | 16495 |
| 3,5 | 375 | 466 | 11405 | 585 | 730 | 17817 |
| 4,0 | 415 | 518 | 12192 | 648 | 811 | 19047 |
| 4,5 | 455 | 570 | 12932 | 711 | 892 | 20202 |
| 5,0 | 496 | 622 | 13632 | 774 | 973 | 21295 |
| 6,0 | 576 | 725 | 14933 | 899 | 1135 | 23328 |
| 7,0 | 656 | 829 | 16129 | 1024 | 1298 | 25197 |
| 8,0 | 736 | 933 | 17243 | 1149 | 1460 | 26936 |
| 9,0 | 815 | 1036 | 18288 | 1273 | 1622 | 28570 |
| 10,0 | 894 | 1140 | 19278 | 1397 | 1784 | 30116 |
| 12,0 | 1053 | 1347 | 21118 | 1645 | 2109 | 32990 |
| 14,0 | 1211 | 1555 | 22810 | 1891 | 2433 | 35634 |
| 16,0 | 1369 | 1762 | 24385 | 2139 | 2758 | 38094 |
| 18,0 | 1526 | 1969 | 25864 | 2384 | 3082 | 40405 |
| 20,0 | 1684 | 2177 | 27263 | 2631 | 3407 | 42590 |
| 22,0 | 1841 | 2384 | 28594 | 2876 | 3731 | 44669 |
| 24,0 | 2000 | 2592 | 29865 | 3124 | 4056 | 46656 |
| 26,0 | 2157 | 2799 | 31085 | 3370 | 4380 | 48561 |
| 28,0 | 2316 | 3006 | 32258 | 3618 | 4705 | 50394 |
| 30,0 | 2472 | 3214 | 33390 | 3861 | 5029 | 52163 |
| 32,0 | 2630 | 3421 | 34486 | 4109 | 5353 | 53873 |
| 34,0 | | 3628 | 35547 | | 5678 | 55531 |
| 36,0 | | 3836 | 36578 | | 6002 | 57141 |
| 38,0 | | 4043 | 37580 | | 6327 | 58707 |
| 40,0 | | 4250 | 38556 | | 6651 | 60232 |



DISCHARGE CAPACITY

| | | | | | | | | |
|---------|---------|---------|----------|----------|-----------|-----------|-----------|-----------|
| 32 x 50 | 40 x 65 | 50 x 80 | 65 x 100 | 80 x 125 | 100 x 150 | 125 x 200 | 150 x 250 | 200 x 300 |
| 25 | 32 | 40 | 50 | 63 | 77 | 93 | 110 | 155 |
| 491 | 804 | 1257 | 1964 | 3117 | 4657 | 6793 | 9503 | 18870 |

For other, not so dense liquids, other than water at 20 °C apply:

I - Saturated steam in kg/h.

II - Air at 0 °C and 1,013 bar in [Nm³/h].

III - Water at 20 °C in l/h.

$$\sqrt{\frac{\rho_A}{\rho_L}} \cdot V_A \text{ ó } V_A = V_L \cdot \sqrt{\frac{\rho_L}{\rho_A}}$$

V_A = Water flow according to table.
 V_L = Liquid flow.
 ρ_A = Water density at a 20 °C.
 (ρ_A = 998 kg/m³)
 ρ_L = Liquid density

| I | II | III | I | II | III | I | II | III | I | II | III | I | II | III | I | II | III | I | II | III | I | II | III | | | | |
|------|-------|-------|------|-------|--------|-------|-------|--------|-------|-------|--------|-------|-------|--------|-------|-------|--------|-------|-------|--------|-------|-------|--------|-------|--------|---------|--|
| 246 | 294 | 10530 | 402 | 482 | 17243 | 629 | 738 | 26958 | 982 | 1168 | 42120 | 1559 | 1845 | 66848 | 2330 | 2773 | 99876 | 4488 | 6470 | 126790 | 6278 | 9051 | 178083 | 11827 | 17051 | 353617 | |
| 369 | 435 | 14892 | 604 | 724 | 24385 | 945 | 1134 | 38125 | 1476 | 1771 | 59568 | 2343 | 2811 | 94538 | 3500 | 4200 | 141246 | 5877 | 9018 | 179308 | 8222 | 12615 | 251847 | 15490 | 23766 | 500090 | |
| 488 | 590 | 18239 | 799 | 960 | 29866 | 1249 | 1498 | 46693 | 1952 | 2342 | 72955 | 3097 | 3716 | 115785 | 4628 | 5431 | 172990 | 7262 | 11272 | 219606 | 10159 | 15769 | 308449 | 19139 | 29707 | 612483 | |
| 602 | 728 | 21060 | 986 | 1191 | 34486 | 1541 | 1863 | 53916 | 2408 | 2913 | 84241 | 3821 | 4622 | 133697 | 5709 | 6907 | 199752 | 8644 | 13527 | 253580 | 12092 | 18923 | 356166 | 22779 | 35649 | 707235 | |
| 708 | 857 | 23546 | 1160 | 1415 | 38556 | 1813 | 2194 | 60280 | 2833 | 3429 | 94185 | 4496 | 5444 | 149478 | 6717 | 8134 | 223329 | 10013 | 15781 | 283511 | 14008 | 22077 | 398206 | 26389 | 41590 | 790712 | |
| 817 | 1017 | 25793 | 1337 | 1664 | 42236 | 2090 | 2605 | 66034 | 3266 | 4070 | 103174 | 5184 | 6376 | 163746 | 7745 | 9526 | 244645 | 11382 | 18036 | 310570 | 15923 | 25231 | 436212 | 29997 | 47531 | 866182 | |
| 916 | 1145 | 27860 | 1499 | 1872 | 45620 | 2343 | 2931 | 71325 | 3661 | 4579 | 111441 | 5811 | 7260 | 176865 | 8682 | 10820 | 264247 | 12744 | 20290 | 335454 | 17828 | 28385 | 471163 | 33585 | 53473 | 935583 | |
| 1014 | 1272 | 29784 | 1660 | 2080 | 48770 | 2596 | 3256 | 76249 | 4056 | 5088 | 119136 | 6437 | 8066 | 189077 | 9617 | 12023 | 282492 | 14099 | 22545 | 358616 | 19724 | 31539 | 503695 | 37158 | 59414 | 1000181 | |
| 1112 | 1399 | 31590 | 1821 | 2288 | 51729 | 2847 | 3582 | 80874 | 4449 | 5596 | 126362 | 7060 | 8873 | 200547 | 10548 | 13225 | 299628 | 15460 | 24799 | 380369 | 21628 | 34692 | 534249 | 40743 | 65356 | 1060852 | |
| 1210 | 1526 | 33299 | 1982 | 2496 | 54527 | 3099 | 3908 | 85249 | 4842 | 6105 | 133198 | 7684 | 9680 | 211394 | 11481 | 14427 | 315835 | 16812 | 27054 | 400944 | 23519 | 37846 | 563148 | 44306 | 71297 | 1118236 | |
| 1406 | 1780 | 36477 | 2303 | 2913 | 59731 | 3600 | 4559 | 93386 | 5625 | 7123 | 145911 | 8928 | 11293 | 231571 | 13339 | 16832 | 345980 | 19511 | 31563 | 439213 | 27294 | 44154 | 616897 | 51419 | 83180 | 1224966 | |
| 1602 | 2035 | 39400 | 2623 | 3329 | 64517 | 4100 | 5210 | 100868 | 6406 | 8140 | 157602 | 10167 | 12907 | 250125 | 15190 | 19236 | 373701 | 22204 | 36071 | 474404 | 31063 | 50462 | 666325 | 58518 | 95063 | 1323115 | |
| 1797 | 2289 | 42121 | 2942 | 3745 | 68972 | 4600 | 5862 | 107833 | 7187 | 9158 | 168483 | 11406 | 14520 | 267395 | 17041 | 21641 | 399504 | 24889 | 40580 | 507159 | 34818 | 56770 | 712332 | 65592 | 106946 | 1414469 | |
| 1991 | 2544 | 44676 | 3261 | 4161 | 73156 | 5098 | 6513 | 114374 | 7965 | 10176 | 178704 | 12641 | 16133 | 283615 | 18887 | 24045 | 423738 | 27568 | 45089 | 537923 | 38566 | 63077 | 755542 | | | | |
| 2185 | 2798 | 47092 | 3578 | 4577 | 77113 | 5594 | 7164 | 120561 | 8740 | 11193 | 188370 | 13871 | 17747 | 298957 | 20724 | 26450 | 446659 | 30230 | 49598 | 567021 | 42290 | 69385 | 796411 | | | | |
| 2572 | 3307 | 51587 | 4212 | 5410 | 84473 | 6585 | 8467 | 132068 | 10289 | 13228 | 206349 | 16329 | 20974 | 327491 | 24396 | 31259 | 489290 | 35579 | 58616 | 621141 | | | | | | | |
| 2958 | 3816 | 55720 | 4843 | 6242 | 91241 | 7572 | 9770 | 142650 | 11830 | 15264 | 222883 | 18775 | 24201 | 353731 | 28052 | 36068 | 528494 | | | | | | | | | | |
| 3344 | 4324 | 59568 | 5476 | 7074 | 97541 | 8561 | 11073 | 152490 | 13376 | 17299 | 238272 | 21229 | 27427 | 378154 | 31718 | 40877 | 564984 | | | | | | | | | | |
| 3727 | 4833 | 63181 | 6103 | 7907 | 103458 | 9542 | 12375 | 161750 | 14909 | 19334 | 252725 | 23661 | 30654 | 401093 | 35352 | 45687 | 599256 | | | | | | | | | | |
| 4113 | 5342 | 66599 | 6736 | 8739 | 109054 | 10531 | 13678 | 170499 | 16454 | 21369 | 266396 | 26113 | 33881 | 422790 | | 50496 | 631671 | | | | | | | | | | |
| 4497 | 5851 | 69850 | 7364 | 9571 | 114377 | 11514 | 14981 | 178821 | 17989 | 23404 | 279398 | | 37108 | 443425 | | | | | | | | | | | | | |
| 4884 | 6360 | 72956 | 7998 | 10400 | 119463 | | 16284 | 186772 | 19537 | 25440 | 291822 | | 40334 | 463142 | | | | | | | | | | | | | |
| 5269 | 6868 | 75934 | | 11236 | 124341 | | 17586 | 194399 | | 27475 | 303738 | | 41948 | 482054 | | | | | | | | | | | | | |
| 5657 | 7377 | 78801 | | 12068 | 129035 | | 18889 | 201737 | | 29510 | 315204 | | | | | | | | | | | | | | | | |
| 6038 | 7886 | 81567 | | 12900 | 133563 | | 20192 | 208818 | | 31545 | 326267 | | | | | | | | | | | | | | | | |
| | 8395 | 84242 | | 13733 | 137944 | | 21494 | 215665 | | 33580 | 336967 | | | | | | | | | | | | | | | | |
| | 8904 | 86834 | | | | | | | | | | | | | | | | | | | | | | | | | |
| | 9412 | 89352 | | | | | | | | | | | | | | | | | | | | | | | | | |
| | 9667 | 91800 | | | | | | | | | | | | | | | | | | | | | | | | | |
| | 10430 | 94185 | | | | | | | | | | | | | | | | | | | | | | | | | |

Calculus according to ISO-4126-1:2004
 "Safety valves".

**FACT LIST FOR
SAFETY VALVE CALCULS**

Calculus according to ISO-4126-1:2004 "Safety valves" 1)

Customer:

Theme:

Leaf:

Of:

| | | | | | | |
|----|-------------------------------|--|----------------------------|--|--|--|
| 1 | Consultation / Bid / Order | | | | | |
| 2 | Position N°. | | | | | |
| 3 | N°. of units | | | | | |
| 4 | Regulation | | | | | |
| 5 | SERVICE CONDITIONS | Fluid | | | | |
| 6 | | Calculation temperature °C | | | | |
| 7 | | State at moment of dischar. l = liquid, s = steam, g = gas | | l <input type="checkbox"/> s <input type="checkbox"/> g <input type="checkbox"/> | l <input type="checkbox"/> s <input type="checkbox"/> g <input type="checkbox"/> | l <input type="checkbox"/> s <input type="checkbox"/> g <input type="checkbox"/> |
| 8 | | Molecular mass kg/kmol | | | | |
| 9 | | Adiabatic exponent æ | Compressibility coe. Z | | | |
| 10 | | Density at moment of discharge kg/m³ | | | | |
| 11 | | Coefficients ψ max | χ | | | |
| 12 | | Viscosity cSt | cPs | | | |
| 13 | | Working pressure abs. bar | | | | |
| 14 | | Set pressure abs. bar | | | | |
| 15 | | External back pressure abs. | | | | |
| | | | constant | variable | bar | |
| 16 | | Rated pressure abs. bar | | | | |
| 17 | | Discharge | Required: kg/h, Nm³/h, l/h | | | |
| 18 | capacity | Possible: 1) Kg/h, Nm³/h, l/h | | | | |
| 19 | VALVE CONSTRUCTION | Opening: Full lift / Normal / Progressive | | | | |
| 20 | | Manufacturer type | | | | |
| 21 | | Materials | Body | | | |
| 22 | | | Seat | | | |
| 23 | | | Plug | | | |
| 24 | | | Spring | | | |
| 25 | | | Joint | | | |
| 26 | | Manual discharge action | | yes / no | | |
| 27 | | Cover | | Closed / Open | | |
| 28 | | Bellows | | si / no | | |
| 29 | | Body with drainage | | si / no | | |
| 30 | | Diameter of narrowest flow d _o | | mm | | |
| 31 | | Section of narrowest flow A _o | Necessary A _o | | mm² | |
| 32 | | | Chosen A _o | | mm² | |
| 33 | Allowed discharge coefficient | | αd | | | |
| 34 | CONNECTIONS | Input / Output | DN | Flange | mm | |
| 35 | | | | Thread | inch | |
| 36 | | | | Welding (soldering) ends | | |
| 37 | | PN | bar | | | |
| 38 | | Shape of joint surfaces (DIN-2526) | | | | |
| 39 | OBSERVATIONS | Unit weight | | approx. Kg | | |
| 40 | | | | | | |
| 41 | | | | | | |
| 42 | | | | | | |
| 43 | ACCEPTANCE | Certificate according to | | EN-10204 2.2 | | |
| 44 | | Certificate according to | | EN-10204 3.2 | | |
| 45 | | | | | | |

Date:

Department:

Name: