



Válvula de seguridad de apertura normal. (AN)

Mod. 385 | ASME | USCS



EP



AP



ES

Funcionamiento

La válvula trabaja como un regulador automático de alivio de presión actuando por la presión estática existente en la entrada de la válvula y se caracteriza por una primera fase de apertura progresiva y una posterior apertura total instantánea.

Normativa

- PED 2014/68/EU
- UNE-EN ISO 4126-1
- UNE-EN 12516-2
- ASME B1.20.1
- ASME VIII Div.1/API 520

Especificaciones

Tamaño

- 1/4" x 1" a 1 1/4" x 2"

Rango de temperatura

- -76 °F hasta +500 °F

Aplicaciones

- Gas, vapor y líquido

Materiales

- Acero al carbono
- Acero inoxidable

Máxima presión

- Hasta 1015 psi

Certificados



Nº. PIEZA	PIEZA	MATERIAL	
		ACERO AL CARBONO	ACERO INOXIDABLE
1	Cuerpo	Acero al carbono (SA-216 Gr. WCB)	Acero inoxidable (SA-351 Gr. CF8M)
2	Campana	Acero al carbono (SA-216 Gr. WCB)	Acero inoxidable (SA-351 Gr. CF8M)
3	Caperuza	Acero al carbono (AISI 1045) (1)	Acero inoxidable (AISI 303) (2)
4	Obturador	Acero inoxidable (AISI 316)	Acero inoxidable (AISI 316)
5	Elevador	Acero inoxidable (AISI 316)	Acero inoxidable (AISI 316)
6	Asiento	Acero inoxidable (SA-479 Gr. 316)	Acero inoxidable (SA-479 Gr. 316)
7	Tapón purga	Acero inoxidable (SA-479 Gr. 316)	Acero inoxidable (SA-479 Gr. 316)
8	Guía	Acero inoxidable (SA-479 Gr. 316)	Acero inoxidable (SA-479 Gr. 316)
9	Eje	Acero inoxidable (SA-479 Gr. 316)	Acero inoxidable (SA-479 Gr. 316)
10	Tornillo hueco	Acero inoxidable (AISI 303)	Acero inoxidable (AISI 303)
11	Tuerca tornillo hueco	Acero inoxidable (AISI 303)	Acero inoxidable (AISI 303)
12	Pistón (EP)	Acero inoxidable (AISI 303)	Acero inoxidable (AISI 303)
13	Pasador	Acero inoxidable (AISI 301)	Acero inoxidable (AISI 301)
14	Muelle	Acero inoxidable (AISI 301)	Acero inoxidable (AISI 301)
15	Muelle pistón (EP)	Acero inoxidable (AISI 301)	Acero inoxidable (AISI 301)
16	Prensamuelle	Acero inoxidable (AISI 304)	Acero inoxidable (AISI 304)
17	Separador	Acero inoxidable (AISI 304)	Acero inoxidable (AISI 304)
18	Palanca	Acero inoxidable (AISI 304)	Acero inoxidable (AISI 304)
19	Anillo (3)	Acero inoxidable (AISI 304)	Acero inoxidable (AISI 304)
20	Junta	PTFE (Teflón)	PTFE (Teflón)
21	Disco cierre	PTFE (Teflón)	PTFE (Teflón)
22	Junta tórica (EP)	Fluoroelastómero (Vitón)	Fluoroelastómero (Vitón)
23	Hilo precintar	Hilo precintar	Hilo precintar
24	Precinto	Plástico	Plástico
NPT1 x NPT2		1/4" x 1" a 1 1/4" x 2"	
CONDICIONES DE SERVICIO	MAWP AIRE / LÍQUIDO [psig]	1015	1015
	MAWP VAPOR SATURADO [psig]	653	653
	TS [°F]	500	500
	ts [°F]	14	-76

(1) Desde 1" x 1 1/2" en Acero al Carbono (EN-1.0619). Versión EP en Acero al Carbono (EN-1.1191)

(2) Desde 1" x 1 1/2" en Acero inoxidable (EN-1.4408). Versión EP en Acero inoxidable (EN-1.4305)

(3) Acero inoxidable (EN-1.4568) para 1/2" x 1" Acero inoxidable (EN-1.4310) para 3/4" x 1 1/4"



Vista isométrica ES

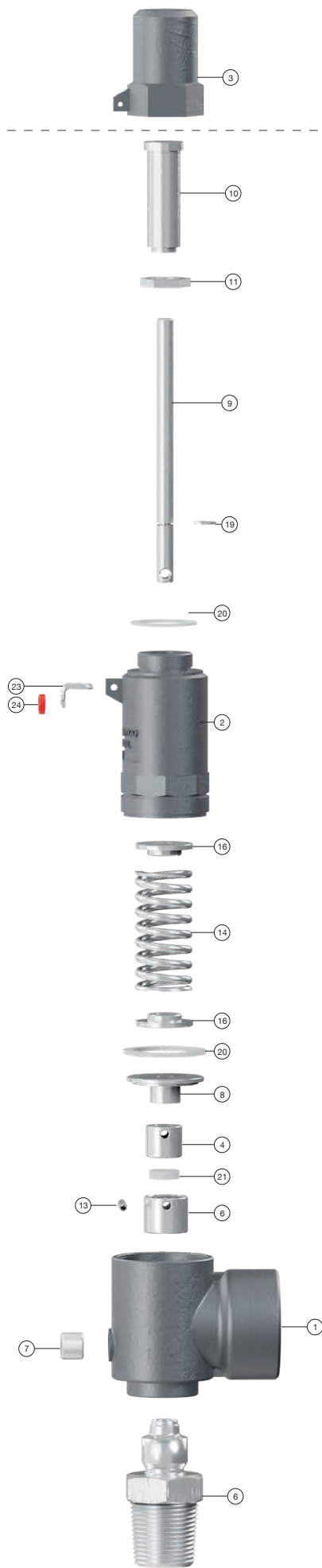

Despiece ES

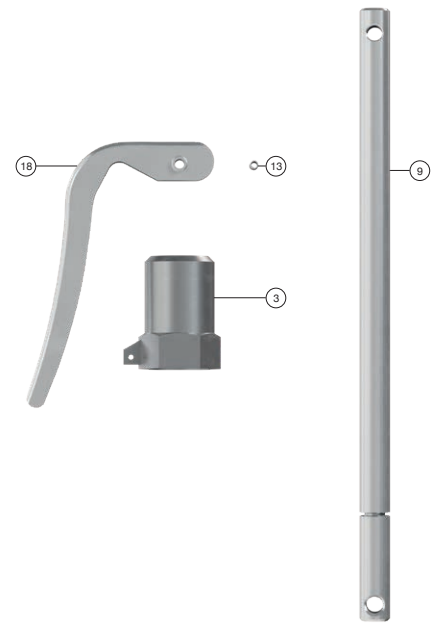

Despiece AP

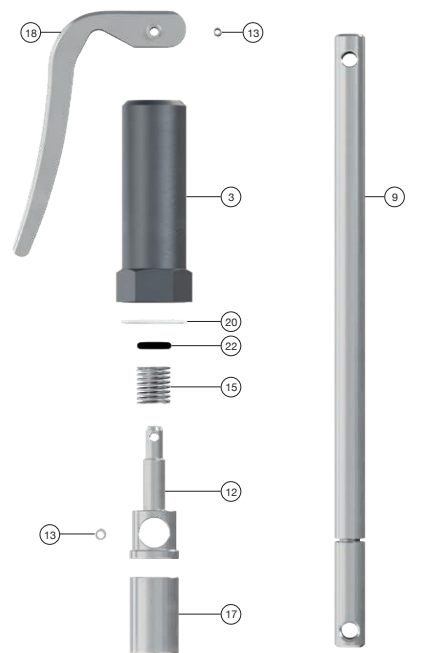

Despiece EP

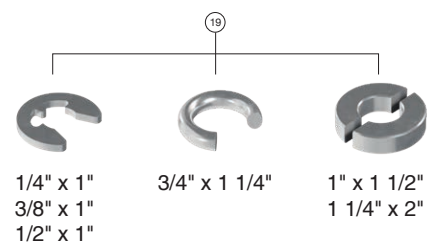

1/4" x 1"
3/8" x 1"
1/2" x 1"

3/4" x 1 1/4"

1" x 1 1/2"
1 1/4" x 2"

Anillos

DIMENSIONES

NPT1 x NPT2		1/4" x 1"			3/8" x 1"			1/2" x 1"			3/4" x 1 1/4"			1" x 1 1/2"			1 1/4" x 2"		
MODELO		ES	AP	EP	ES	AP	EP	ES	AP	EP	ES	AP	EP	ES	AP	EP	ES	AP	EP
d0 [in]		0,30			0,30			0,30			0,30			0,39			0,55		
A0 [in ²]		0,07			0,07			0,07			0,07			0,12			0,24		
H [in]		6,10	6,61	8,07	6,10	6,61	8,07	6,22	6,73	8,19	8,35	8,86	10,20	10,20	10,67	11,93	13,35	13,98	15,31
h1 [in]		1,34			1,34			1,34			1,61			1,89			2,40		
L1 [in]		1,65			1,65			1,65			1,89			2,13			2,68		
L2 [in]		1,73			1,73			1,85			2,32			2,84			3,07		
R		1/8"			1/8"			1/8"			1/8"			1/8"			1/8"		
Rosca Hembra Gas Whitworth cilíndrica UNE-EN ISO 228-1																			
PESO [lb]	ACERO AL CARBONO	1,47	1,55	1,77	1,49	1,59	1,78	1,52	1,60	1,82	2,17	2,25	2,62	5,24	5,43	5,97	10,26	10,54	11,30
	ACERO INOXIDABLE																		
CÓDIGO	ACERO AL CARBONO 2002-385.	00442	00441	00443	03842	03841	03843	00242	00241	00243	03442	03441	03443	01042	01041	01043	01442	01441	01443
	ACERO INOXIDABLE 2002-385.	00422	00421	00423	03822	03821	03823	00222	00221	00223	03422	03421	03423	01022	01021	01023	01422	01421	01423

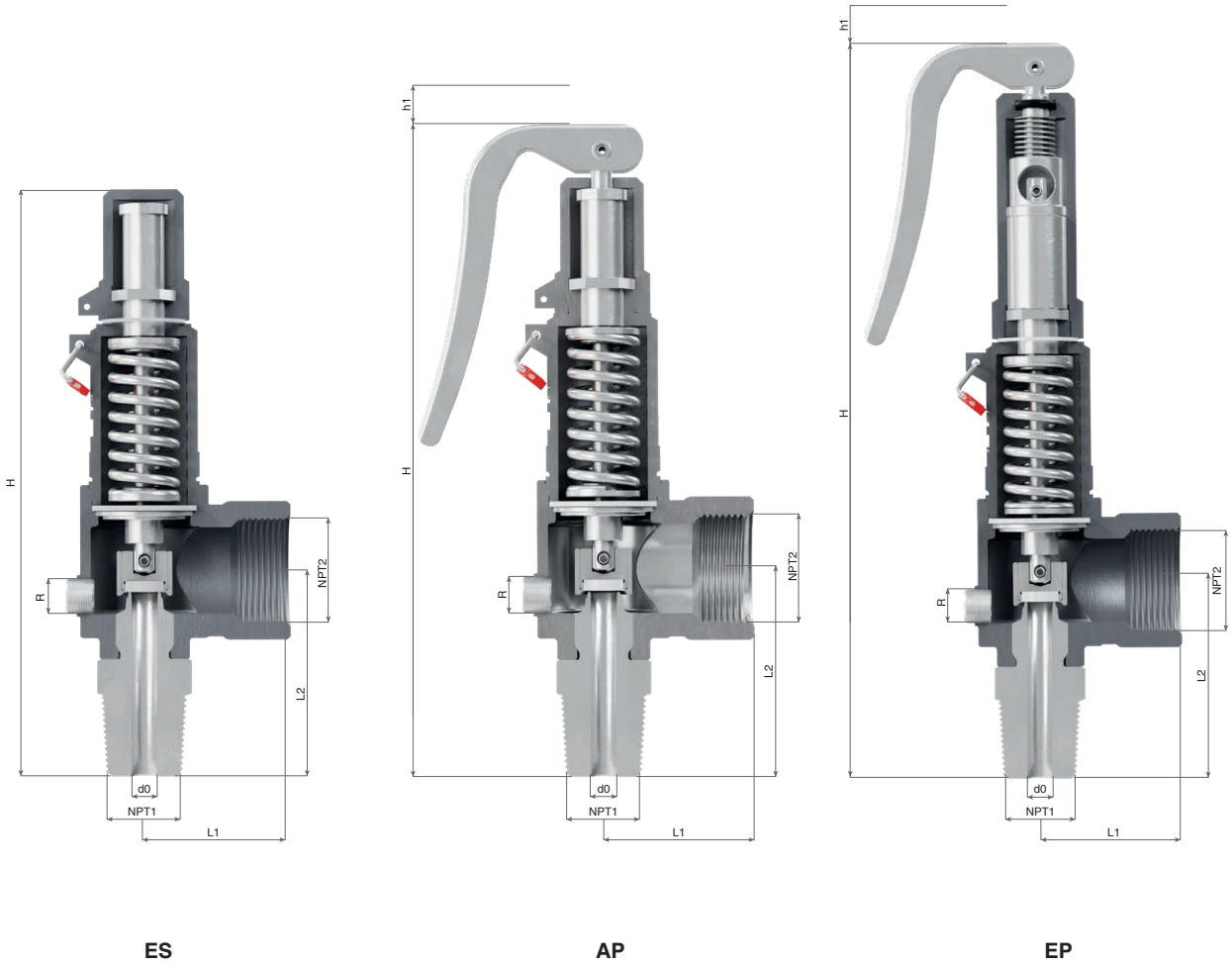

PRESIONES Y CAMPOS DE REGULACIÓN DE LOS MUELLES

NPT1 x NPT2		1/4" x 1" 3/8" x 1" 1/2" x 1"	3/4" x 1 1/4"	1" x 1 1/2"	1 1/4" x 2"	
PRESIONES DE REGULACIÓN [psig]	MÁXIMA (LÍQUIDOS Y GASES)	1015	1015	1015	1015	
	MÁXIMA (VAPOR SATURADO)	653	653	653	653	
	MÍNIMA	VAPOR Y GASES				
		364	364	364	364	
		LÍQUIDOS				
		364	364	364	364	
CAMPOS DE REGULACIÓN DE LOS MUELLES [psig]	364 - 580	CÓDIGO	56127	56129	56132	56135
	532 - 870	CÓDIGO	56128	56130	56133	56136
	812 - 1015	CÓDIGO		56131	56134	56137

COEFICIENTES DE DESCARGA

NPT1 x NPT2		1/4" x 1" 3/8" x 1" 1/2" x 1"	3/4" x 1 1/4"	1" x 1 1/2"	1 1/4" x 2"
d0 [in]		0,30	0,30	0,39	0,55
h [in]		0,09	0,09	0,12	0,16
h/d0 [in]		0,0115	0,0115	0,0118	0,0113
VAPOR Y GASES [Kdr]		0,35	0,62	0,62	0,62
LÍQUIDOS [Kdr]		0,27	0,54	0,54	0,54



Fluidodinámica

SOBREPRESIÓN Y DISMUNICIÓN DE LA PRESIÓN DE REINICIO EN % DE LA PRESIÓN DE REGULACIÓN		
FLUIDO	SOBREPRESIÓN	DISMINUCIÓN DE LA PRESIÓN DE REINICIO
VAPOR SATURADO GAS	10 %	15% o 4,35 psi (El mayor de los dos valores)
LÍQUIDO	10 %	20% o 8,70 psi (El mayor de los dos valores)
CONTRAPRESIÓN INICIAL CONSTANTE		Ajustar el muelle descontando la contrapresión a la presión de regulación
CONTRAPRESIÓN GENERADA		Máx. 10% de la presión de regulación

CAMPOS DE APLICACIÓN RECOMENDADOS				
VERSIÓN		AP	ES	EP
FLUIDO	VAPOR SATURADO	* (1)		*
	GAS	* (1)	*	*
	LÍQUIDO	*	*	*

(1) Si se trabaja con fluidos caros o nocivos emplear únicamente los modelos ES o EP.

CAPACIDADES DE DESCARGA												
NPT1 x NPT2	1/4" x 1" 3/8" x 1" 1/2" x 1"			3/4" x 1 1/4"			1" x 1 1/2"			1 1/4" x 2"		
d0 [in]	0,30			0,30			0,39			0,55		
$A0 = \frac{\pi \cdot d0^2}{4}$ [in ²]	0,07			0,07			0,12			0,24		
p [psig]	I	II	III	I	II	III	I	II	III	I	II	III
364,0	494	178	18	875	315	31	1582	569	56	3147	1132	112
377,0	511	184	18	905	326	32	1637	589	57	3256	1171	114
391,5	530	191	18	939	338	32	1698	611	58	3377	1215	116
406,0	549	197	19	972	350	33	1759	633	59	3498	1258	118
420,5	568	204	19	1006	362	33	1820	654	61	3619	1302	120
435,0	587	211	19	1040	374	34	1880	676	62	3740	1345	122
449,5	606	218	20	1073	386	35	1941	698	63	3861	1389	124
464,0	625	225	20	1107	398	35	2002	720	64	3982	1432	126
478,5	644	232	20	1141	410	36	2063	742	65	4103	1476	128
493,0	663	238	20	1174	422	36	2124	764	66	4224	1519	130
507,5	682	245	21	1208	434	37	2185	786	66	4345	1563	132
522,0	701	252	21	1242	447	37	2245	808	67	4466	1606	134
536,5	720	259	21	1275	459	38	2306	829	68	4587	1650	136
551,0	739	266	22	1309	471	38	2367	851	69	4708	1693	138
565,5	758	273	22	1343	483	39	2428	873	70	4829	1737	140
580,0	777	279	22	1376	495	39	2489	895	71	4950	1780	141
594,5	796	286	22	1410	507	40	2550	917	72	5071	1824	143
609,0	815	293	23	1443	519	40	2611	939	73	5192	1867	145
623,5	834	300	23	1477	531	41	2671	961	74	5313	1911	147
638,0	853	307	23	1511	543	41	2732	983	75	5434	1954	148
652,5	872	314	24	1544	555	42	2793	1005	75	5555	1998	150
667,0		320	24		568	42		1026	76		2041	152
681,5		327	24		580	43		1048	77		2085	153
696,0		334	24		592	43		1070	78		2128	155
710,5		341	25		604	44		1092	79		2172	156
725,0		348	25		616	44		1114	79		2215	158
739,5		355	25		628	44		1136	80		2259	160
754,0		361	25		640	45		1158	81		2302	161
768,5		368	26		652	45		1180	82		2346	163
783,0		375	26		664	46		1201	83		2390	164
797,5		382	26		676	46		1223	83		2433	166
812,0		389	26		689	47		1245	84		2477	167
826,5		396	26		701	47		1267	85		2520	169
841,0		402	27		713	47		1289	86		2564	170
855,5		409	27		725	48		1311	86		2607	172
870,0		416	27		737	48		1333	87		2651	173
884,5		423	27		749	49		1355	88		2694	175
899,0		430	28		761	49		1377	89		2738	176
913,5		436	28		773	49		1398	89		2781	177
928,0		443	28		785	50		1420	90		2825	179
942,5		450	28		797	50		1442	91		2868	180
957,0		457	29		810	50		1464	91		2912	182
971,5		464	29		822	51		1486	92		2955	183
986,0		471	29		834	51		1508	93		2999	184
1000,5		477	29		846	52		1530	93		3042	186
1015,0		484	29		858	52		1552	94		3086	187

■ I - Vapor saturado [lb/h]. **ATENCIÓN:** Caudales de acuerdo ASME VIII Div.1/API 520 con el 10% de sobrepresión.

■ II - Aire a 60 °F y 14,50 psi [S.C.F.M.].

■ III - Agua a 70 °F [US - G.P.M.].